

WIRE WINDING

SYNCHRO DESIGN

# PW611-16d

## Wire wound precision Potentiometer

- High-resolution resistive element with caterpillar winding
- Short-circuit distances and additional taps available upon request
- Suitable for measured value acquisition in small installation spaces



## TECHNICAL DATA

Housing material	aluminum, anodized	Resistance values	to 10 kΩ
Housing diameter	28 mm	Resistance tolerance	5%
IP code of housing up to	IP30	Linearity tolerance	±0.5 %
Shaft diameter	6 mm	Resolution in turns	1369
Adjustment speed	max. 360 U/min	Capacity	0.5 W
Torque	0.04 Ncm	Temperature range	-30 °C to +80 °C
Wiper without limit stops	for adjustment purposes only	Temperature coefficient	0.0017 % / °C
Multiple execution	triple	Lifetime	typical 10–50 Mio. Cycles**
Bearing	sintered bearing	<small>** The lifetime depends on the application and environmental conditions.</small>	
Connection	faston plug / solder-type terminals	Vibration*	5–200 Hz, 10 g
Fastening	clamp fixing	Shock*	50 g, 6 ms
Resistance element	caterpillar		
Active angle	max. 340°		

\*Depending on customer specifications.

**Article master number 1122Z01**

Typical

## APPLICATION AREAS



Ship



Rails



Automation



Logistics



Medicine



Industry

Optionally available

## PROTECTIVE HOUSING

To protect against mechanical damage and extreme environmental conditions, as well as for necessary adaptation gears and additional switches, suitable housings are available in various designs.



**For more information on protective housings, click here: [www.fsg-sensors.de](http://www.fsg-sensors.de)**



WIRE WINDING

SYNCHRO DESIGN

# PW611-16d

## DIMENSIONAL DRAWINGS

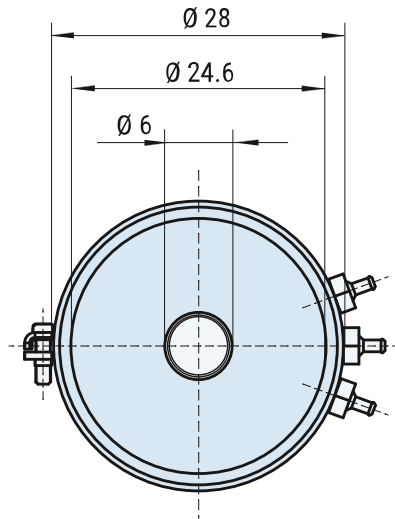
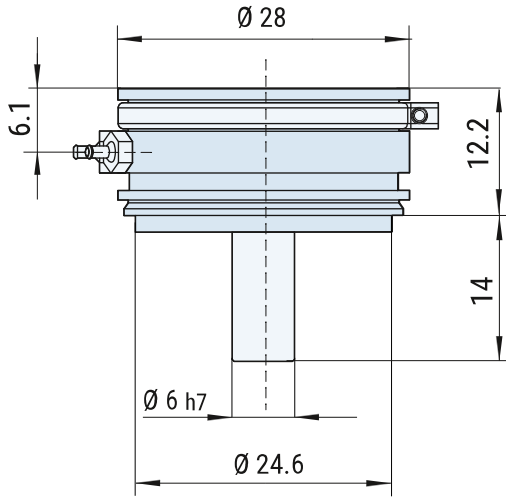

## CONNECTION

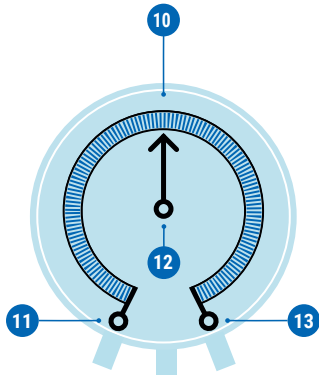

**Standard**

- 11 Resistance start
- 12 Wiper
- 13 Resistance end

**Optional**

- 10 Additional tap

## CIRCUIT VARIATIONS

Wire-wound resistive elements with shape on a painted copper wire body in single-turn or multi-turn potentiometers.



- 1 Wiper limited by stops
- 2 Wiper continuous rotation without limit stops (over 360°) only for short-up without voltage
- 3 Free arrangement of short-circuit sections
- 4 Free arrangement of taps

## CONTACT

If you have any questions about this or any other FSG product, please do not hesitate to contact us.



**BERLIN (HQ)**  
Fernsteuergeräte Kurt Oelsch GmbH  
Jahnstraße 68 + 70  
12347 Berlin

✉ info@fsg-sensors.de  
🌐 www.fsg-sensors.de  
📞 +49 30 6291-1  
📠 +49 30 6291-277

© Fernsteuergeräte Kurt Oelsch GmbH  
No guarantee for the correctness, completeness of the contents. The product illustration may differ from original.